

**BANKNOTE VALIDATOR
AND RECYCLERS**

NV200

Exceptional note handling on banknotes up to 85 mm wide



The NV200 is a secure, field proven banknote validator. With a lockable, removable cashbox that can hold up to 1000 notes it is ideal for global high volume applications. The unit can accept notes at acute angles in all four ways as auto-centering technology straightens notes before reading.

FEATURES

- High volume, high security banknote validator
- Proven field reliability
- Easy maintenance, free firmware updates
- Lockable, removable cashbox which holds up to 1000 notes
- Exceptional performance - auto-centering technology straightens notes before reading
- Accepts banknotes up to 85 mm wide and standard industry barcode tickets

BENEFIT

- Superior note handling - maximises cash efficiency
- Future proof - quick & easy updates via USB, data flash card, PC or handheld programmer
- Lowest cost of ownership
- Reduces operator collection costs
- Takes more cash
- One product suitable for most global applications



**AUTO-CENTERING
TECHNOLOGY**



**REMOVABLE
CASHBOX**

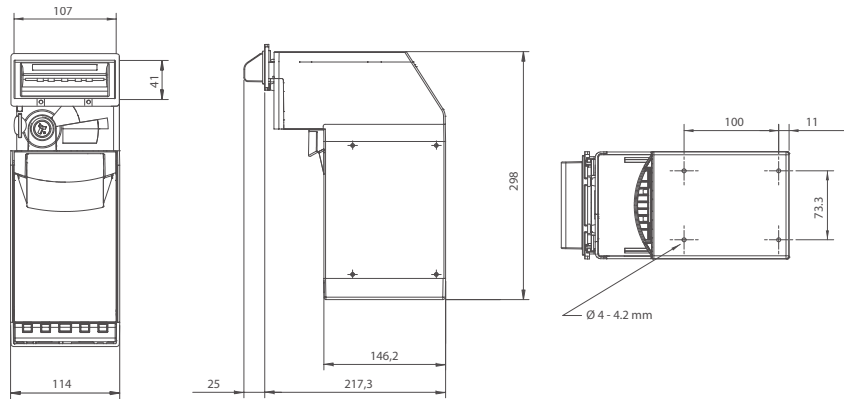

Technical Schematics

NOTE: UNIT OF MEASURE MM

TOOLS

DA2 kit

Kit for programming, configuration and diagnostics

DA3 kit

Kit to pre-configure the SD card or flash card for on site upgrading

DA3 Easy

Easy and intuitive kit for on field programming



OPTIONAL ACCESSORIES

- 2 bezels
- Triple safety lock
- RS232-PC adaptor for the Innovative reader
- IF5: interface for converting the SSP protocol to MDB mode.
- IF10: interface for converting the SSP protocol to parallel mode.
- IF15: interface for converting the SSP protocol to pulse mode

BEZEL OPTIONS

- Standard bezel
- Metal bezel
- Self-aligning bezel
- Various illumination options

PROTOCOLS

- SSP
- ccTalk
- MDB
- IF003

INTERFACES

- USB
- RS232
- Open Collector

TECHNICAL SPECIFICATION

Dimensions (LxHxW)	114 x 298 x 217.3 mm
Weight	3 Kg
Power supply	12 VX +/- 10% (MDB version: min. 23 V - max 42 V)
Current consumption	400 mA in stand-by 1.5 A while running 3 A at peak
Power consumption	480 mW in stand-by 18 W while running 36 W at peak
Operating temperature	3 °C ÷ 50 °C - 5 ÷ 95% humidity non-condensed
Banknotes accepted	width 60 – 85 mm, length 115 – 170 mm
Acceptance speed	3 seconds
Capacity	Cashbox: 500 or 1,000 banknotes
MCBF	200,000